

GUJARAT TECHNOLOGICAL UNIVERSITY**B.E. Sem-II [All Branch] examination June 2009****Subject code: 110013****Subject Name: Engineering Graphics****Date: 19/06/2009****Time: 10:30am-1:30pm****Total Marks: 70****Instructions:**

1. Attempt all questions.
2. Make suitable assumptions wherever necessary.
3. Figures to the right indicate full marks.
4. Use both the side of answer sheet.
5. Lines, dimensions etc. should be as per BIS SP-46
6. Retain all construction lines.
7. All dimensions are in mm.
8. Figures/sketches are not to the scale.
9. Neatness is expected.

Q.1

- (a) **Figure 1** shows the three dimensional pictorial view of an object. **07**
Draw using first angle projection method, front view, top view and side view.
- (b) **Figure 2** shows two views of an object. Draw using first angle **07**
projection method, sectional elevation and plan.

Q.2

- (a) Draw Isometric view for the object shown in **Figure 3**. **07**
- (b) **Figure 4** shows an offset slider crank mechanism. Crank OB is 30 **07**
mm long and rotates in clockwise direction. Connecting rod AB is 128 mm long. Offset is 40 mm. Draw the loci of two points P and R. PB and RK are 45mm and 30 mm respectively.

OR

- (b) i) Construct a plain scale to show kilometers and hectometers when **04**
25 mm is equal to 1 km and long enough to measure up to 6 km. Find RF and show a distance of 3km and 4 hectometer on the scale.
- ii) Draw an isometric scale and show a measurement of 46mm on **03**
the scale.

Q.3

- (a) The distance between end projectors of a straight line PQ is 130 mm **07**
point P is 40mm below H.P. and 25 mm in front of V.P. Point Q is 75 mm above H.P. and 30 mm behind V.P. Draw the projection of a line and find out its true length and inclination with H.P. and V.P.
- (b) ABCDE is a regular pentagonal plate of 40mm sides, has its corner **07**
A on the H.P. the plate is inclined at 30° to the H.P. such that the side CD is parallel to both the reference planes. Draw the projection of plate.

OR

- Q.3** (a) The front view of a line AB, 90mm long, measures 65mm. Front **07**
view is inclined to XY line by 45°. Point A is 20mm below H.P. and on V.P. Point B is in third quadrant. Draw the projections and find inclinations of line with H.P. and V.P.

- (b) A square plate of side 60mm is held on a corner on H.P Plate is inclined to the H.P. such that the plan of it is rhombuses with a diagonal of 30mm. determine the angle it makes with H.P. The other diagonal is inclined at 45° V.P. Draw the projection of plate. **07**
- Q.4**
- (a) A pentagonal prism is resting on one of the corner of its base on the H.P. The longer edge containing that corner is inclined at 45° to the H.P. The axis of the prism makes an angle of 30° to the V.P. Draw the projections of the solid. **07**
- (b) A square pyramid, base 40 mm side and axis 65mm long, has its base on the H.P. And all the edges of the base equally inclined to the V.P. It is cut by a section plane perpendicular to the V.P. inclined at 45° to the H.P. and bisecting the axis. Draw its sectional top view, sectional side view ant true shape of the section. **07**
- OR**
- Q.4** (a) A Hexagonal prism is resting on one of its side of base (30mm), such that axis(60mm) is inclined at 45° to H.P. and the side on which it is resting is inclined at 30° to V.P. Draw the projections. **07**
- (b) A cylinder 40mm diameter and 70mm height is resting on its base on H.P. It is cut by plane passing through a point 50mm from the base and inclined at 40° to H.P. A through hole of 20mm diameter is drill at 30mm above the base. **07**
- Develop the lateral surface of the cylinder.
- Q.5**
- (a) Draw the development of lateral surface of a right circular cone having base diameter 40 mm and length of axis 60 mm, when it is resting on H.P. and cut by an AIP inclined at 45° to the H.P. and bisecting the axis. **07**
- (b) A square pyramid, side of base 30 mm and axis length 50 mm is resting on the H.P. on its base with all sides equally inclined to V.P. it is cut by an AIP inclined at 45° to the H.P. and bisecting the axis. Draw development of lateral surface of the pyramid. **07**
- OR**
- Q.5** (a) Two points A and B are 100 mm apart. Third point C is 75mm from A and 50mm from B. Draw an ellipse passing through A, B &C. **07**
- (b) An elastic string is unwounded to a length of 120 mm from a drum of diameter 30 mm. Draw the locus of the free end of the string which is held tight during unwinding. **07**

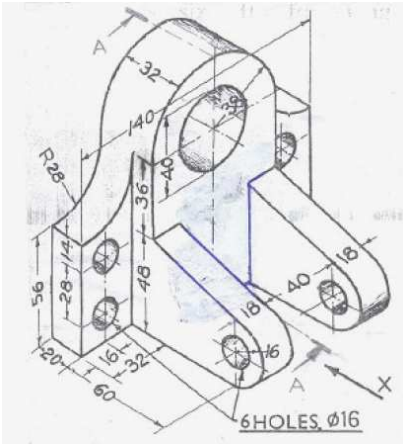

Figure 1

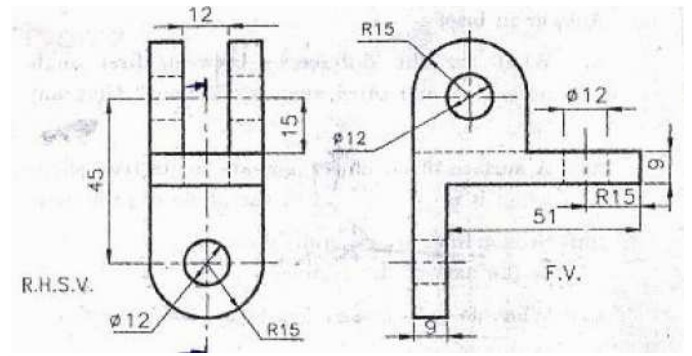

Figure 2

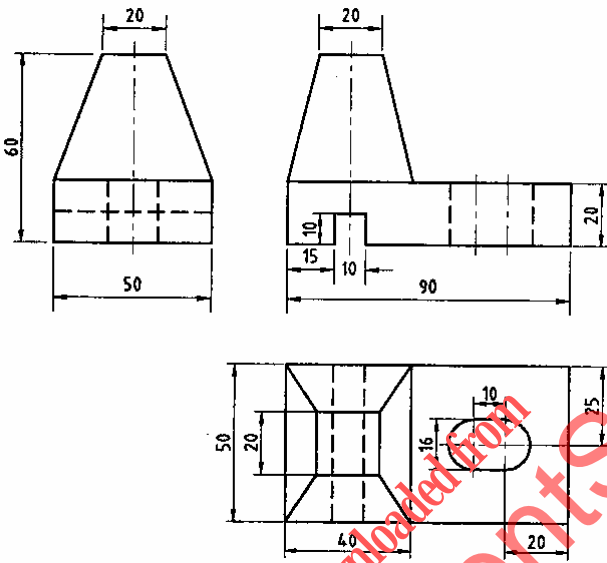

Figure 3

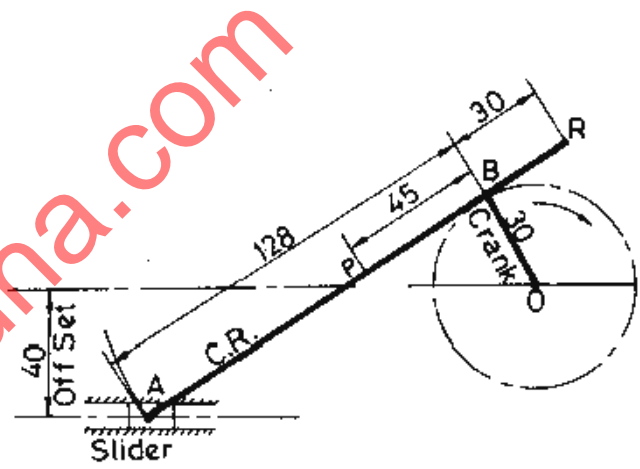

Figure 4