

GUJARAT TECHNOLOGICAL UNIVERSITY
BE - SEMESTER- 1st / 2nd • EXAMINATION – SUMMER • 2014

Subject Code: 110010**Date: 26-06-2014****Subject Name: Mechanics of Solids****Time: 02:30 pm - 05:30 pm****Total Marks: 70****Instructions:**

1. Attempt any five questions.
2. Make suitable assumptions wherever necessary.
3. Figures to the right indicate full marks.

- Q.1 (a)** Fill in the blanks with the most appropriate answer. Write complete sentence with the answer. **07**
- 1) Three coplanar non-parallel forces in equilibrium will _____ be concurrent. [always, never, sometimes]
 - 2) A M.S. bar under tension test shows the property of _____. [malleability, ductility, tension ability]
 - 3) Which one of the expression is not true _____.
 [$E=2G(1+\mu)$, $E=3K(1-2\mu)$, $E=9KG/(3G+K)$, $M= I/Y$]
 - 4) Point of contraflexure is where _____. [shear force is zero, shear force changes sign, B.M.is zero, B.M. changes sign]
 - 5) The shape of shear force diagram for cantilever beam subjected to couple at free end is _____. [horizontal straight line, zero, parabola, hexagonal]
 - 6) All joints in a truss are _____ joints. [pin, fixed, rigid]
 - 7) On oiling the lifting machine _____ is NOT affected. [velocity ratio, mechanical advantage, efficiency, law of machine]
- (b)** Define Hardness, Toughness, Equilibrant, Poisson's ratio, Perfect truss, Bulk modulus of elasticity and Particle. **07**
- Q.2 (a)** Determine the resultant of the forces acting on the board as shown in figure 1. **06**
- (b)** The extremities A & D of a light inextensible string ABCD are tied to two points in the same horizontal line. Weight W & 3W are tied to the string at the points B & C resp. of AB & CD are inclined to the vertical at angles 60° & 30° resp. Show that BC is horizontal & find the tensions in the various parts of the string as shown in figure 2. **08**
- Q.3** A beam is loaded as shown in figure 3
- 1) Determine the reactions at supports **07**
 - 2) Draw S.F diagram for the beam **03**
 - 3) Draw B.M diagram for the beam & determine the magnitude of maximum B.M. **04**
- Q.4** A section of beam as shown in figure 4 is subjected to a B.M of 10 KN m about the major axis & A S.F of 20KN.
- 1) Determine the M.I. of the section about both the centroid axis. **07**
 - 2) Draw bending stress distribution across the section. **03**
 - 3) Draw shear stress distribution across the section **04**

- Q.5** A truss is loaded as shown in figure 5. Determine
- 1) The support reactions **06**
 - 2) Internal forces in the members. **08**
- Q.6** (a) A 5m long ladder & 250N weight is placed against a vertical wall in a position where it's inclination to the vertical is 30° . A man weighing 800N climbs the ladder. At what position will he induce slipping? The coefficient of friction between floor & ladder is 0.2 & that between vertical wall & ladder is also 0.2. **07**
- (b) For an element as shown in figure 6. Find 1) Principal stresses & location of corresponding principal planes 2) Maximum shear stress & location of planes containing it. **07**
- Q.7** (a) The V.R of the lifting machine is 50. By this machine to lift a load of 4000N an effort of 100N is required .Find (a) MA, (b) η of M/C, (c) is the M/C reversible or self locking and (d) if reversible, what maximum effort should be applied to prevent reversal of motion. **07**
- (b) A rectangular block of material is 250 mm long, 100mm wide and 80mm thick. If it is subjected to a tensile load of 200kN, compressive load of 300kN and tensile load of 250kN along its length, width and thickness respectively. Find the change in volume of the block. Take $E= 210\text{GPa}$ and Poisson's ratio $\mu=0.25$. **07**

downloaded from
StudentSuvidha.com

SKETCHES

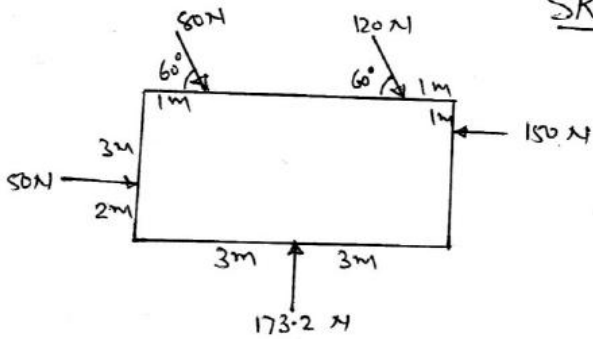

Q. 2 (a) Figure : 1

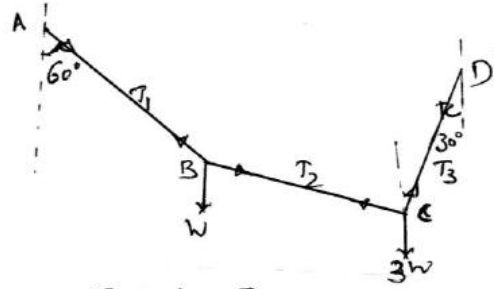

Q. 2 (b) Figure : 2

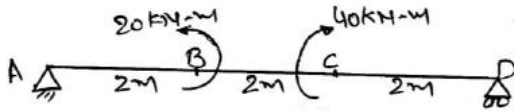

Q. 3 Figure : 3

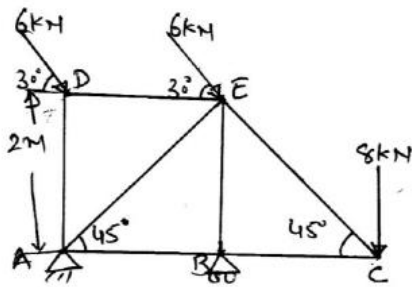

Q. 5 Figure : 5

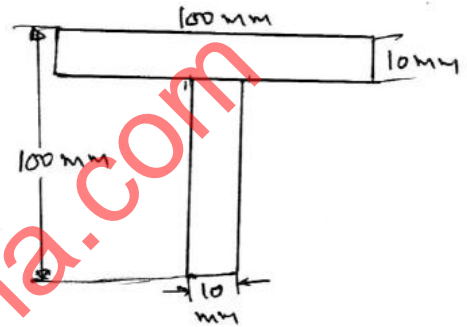

Q. 4 Figure : 4

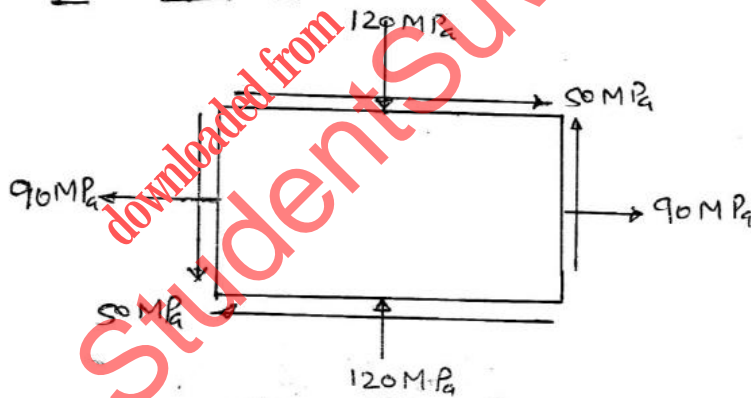

Q. 6 (b) Figure : 6
