

GUJARAT TECHNOLOGICAL UNIVERSITY

B.E. First Semester Examination January 2010

Subject Code : 110005

Subject Name: Elements of Electrical Engineering

Date: 06 / 01 / 2010

Time: 11.00 am – 1.30pm

Total Marks: 70

Instructions:

1. Attempt all questions.
2. Make suitable assumptions wherever necessary and justify the same.
3. Figures to the right indicate full marks.

- Q.1 (a)** Calculate the current flowing through the $10\ \Omega$ resistor of circuit shown below, by using any method. Values of resistors are in ohm. **05**

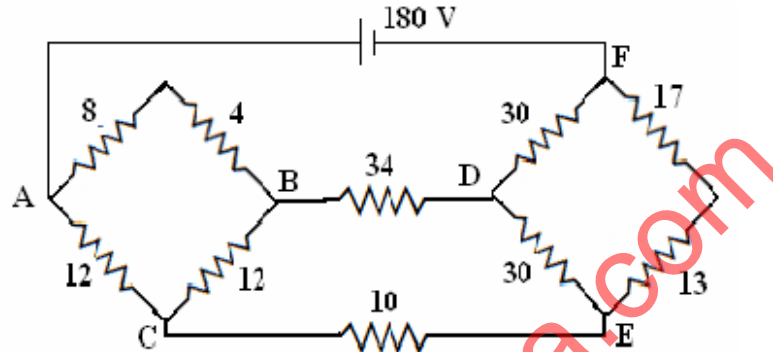

- (b)** Calculate the value of branch currents for the network shown below, using nodal analysis. Values of resistors are in ohm. **05**

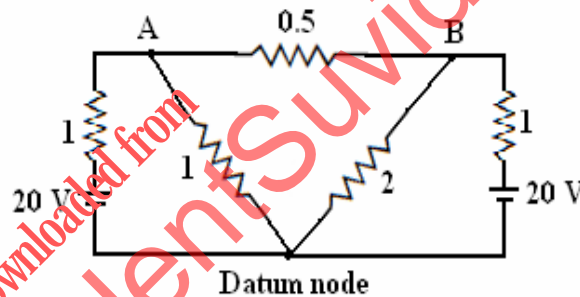

- (c)** Giving reason in brief, state the effect of increase in temperature on the resistance of (i) pure metals (ii) insulators (iii) semiconductors **04**
- Q.2 (a)** With reference to electrostatic and capacitance: (i) State Coulomb's laws **07**
 (ii) Define:- (a) electric field intensity (b) electric potential
 (c) potential gradient (d) permittivity (e) capacitance
- (b)** Three capacitors have capacitance of 10, 50 and 25 μF . **07**
 Calculate: (i) charge on each capacitor when they are connected in parallel to a 250 V supply (ii) total capacitance and (iii) potential difference across each capacitor when they are connected in series.

OR

- (b)** A resistor of $2\ \text{M}\Omega$ is connected in series with a capacitor of $0.01\ \mu\text{F}$ across d.c. voltage source of 50 V. Calculate: (a) capacitor voltage after 0.02 sec, 0.04 sec, 0.06 sec and 1 hour. (b) charging current after 0.02 sec, 0.04 sec, 0.06 sec and 0.1 sec. **07**
- Q.3 (a)** State similarities and dissimilarities between electric circuit and magnetic circuit. **05**
- (b)** Draw B-H curve (Magnetising curve) of a magnetic material and label the figure. Define all the terms relevant to this curve. **05**

- (c) State Faraday's laws of electromagnetic induction. What do you understand by statically induced emf and dynamically induced emf? 04

OR

- Q.3 (a) A mild steel ring of 30 cm mean circumference has a cross-section area of 6 cm^2 and has a winding of 500 turns on it. The ring is cut through at a point so as to provide an air-gap of 1 mm in the magnetic circuit. It is found that a current of 4 A in the winding, produces a flux density of 1 tesla in the air-gap. Calculate: (i) the relative permeability of the mild steel and (ii) inductance of the winding. 05
- (b) A d.c. current of 1 ampere is passed through a coil of 5000 turns and produces a flux of 0.1 mWb. Calculate the inductance of the coil. What would be the voltage developed across the coil if the current were interrupted in 10^{-3} second? Find the energy stored in the coil. What would be the maximum voltage developed across the coil if a capacitor of $10 \mu\text{F}$ were connected across the switch interrupting the d.c. current? 05
- (c) State the components of iron loss taking place in the magnetic circuit. Also state the remedies to reduce these losses. 04

- Q.4 (a) Add the following currents as waves and as vectors
 $i_1 = 7 \sin \omega t$ and $i_2 = 10 \sin (\omega t + \pi/3)$ 05
- (b) Voltage and current for a circuit with two pure elements in series are expressed as follows:
 $v(t) = 170 \sin (6280 t + \pi/3)$ volts
 $i(t) = 8.5 \sin (6280 t + \pi/2)$ amps
Sketch the two waveforms. Determine: (i) the frequency (ii) power factor stating its nature (iii) values of the elements. 05
- (c) An inductive coil draws 10 A current and consume 1 KW power from a 200 V, 50 Hz, a. c. supply. Determine: (i) the impedance in cartesian and polar form (ii) power factor (iii) reactive and apparent power. 04

OR

- Q.4 (a) Two impedances given by $Z_1 = (10 + j5) \Omega$ and $Z_2 = (8 + j6) \Omega$ are connected in parallel across a voltage of $V = (200 + j0)$ volts. Calculate the circuit current, branch currents and power factor of each branch. Sketch the vector diagram with vectors in appropriate proportion. 07
- (b) Explain the phenomena of resonance in a.c. parallel circuit. Derive the mathematical expression of resonant frequency. Sketch the graphical representation of parallel resonance. 07
- Q.5 (a) Derive the relation between phase and line values of voltages and currents in case of 3-phase (i) star (ii) delta connection. 05
- (b) Prove that the sum of readings of two wattmeters connected to measure power in 3-phase a.c. circuit, gives total power consumed by the circuit. 05
- (c) Using schematic block diagram, briefly explain charging of battery from a.c. supply mains. 04

OR

- Q.5 (a) Three 100Ω non-inductive resistances are connected in (a) star (b) delta, across a 400 V, 50 Hz, 3-phase supply mains. Calculate the power taken from the supply system in each case. 05
- (b) Draw a schematic block diagram showing positioning of major equipments in domestic wiring. Label the diagram. Also draw the circuit for controlling one lamp from two points (stair case wiring). 05
- (c) Give comparison between fuse and MCB with regard to protection in wiring installation. 04
